

CREATION OF COMPREHENSIVE SPECIFICATION OF SPECIAL CNC MACHINE DESIGN SOLUTION

Darina Duplakova*, Jan Duplak, Svetlana Radchenko, Zuzana Mitalova

Technical University of Kosice, Faculty of Manufacturing Technologies with a seat in Presov,
Institute of Advanced Technologies, Bayerova 1, 080 01 Presov, Slovakia
darina.duplakova@tuke.sk

ABSTRACT

The conventional CNC machines are based on known design solutions in which the main production material is steel. At present, the field of material engineering has a wide range of new materials which raises the question of whether these materials can be used as a design element for CNC machines. At the same time, it is necessary to aware that it is required to develop special construction procedures for these materials. This paper focuses on the creation of comprehensive specifications of special CNC machine design solutions. The introduction part of the article provides a theoretical level of issue general knowledge and subsequently in the next part is described the specifications of design solutions of special CNC machines with a practical example of a selected example. The conclusion of the article is devoted to a comprehensive summary of the issues. This work was supported by the Slovak Research and Development Agency under the contract No. APVV-15-0700.

Keywords: CNC machine; polymer concrete; design solution.

INTRODUCTION

Continual science and technology development are characteristic of today's every technical field, including the engineering industry. The present-day is based on progressive technologies that are automated and use materials whose properties are better than commonly available materials (Antić, et al., 2013; Kojic, et al., 2015; Mitalova et al., 2020). Every product that wants to be part of production trends has to meet all the requirements (Behunova, et al., 2018; Panda et al., 2017). The basic design attributes that characterize CNC machines include (Poklemba et al., 2020) (Figure 1):

- ensures the economy of the cutting mode in automatic operation with high productivity
- high strength and rigidity of guide surfaces
- ensuring the exact position of the machine nodes or their parts (servomechanisms and measuring devices forming the positioning control circuit)
- suitability of the construction to ensure quick and easy replacement of parts susceptible to higher wear
- application of ball screws.

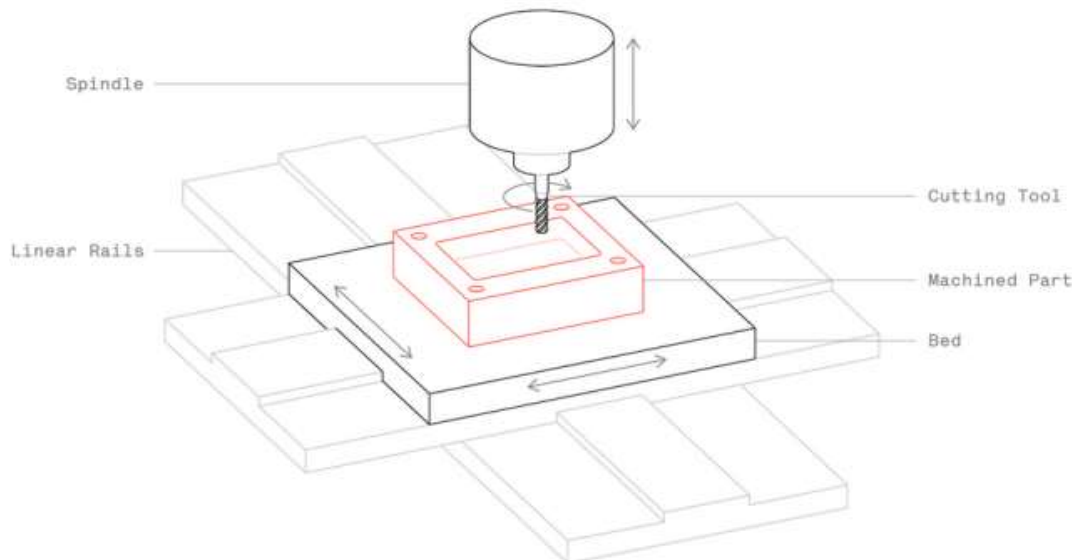

Figure 1. CNC milling machine – diagram (Alkaios, 2019)

DESIGN SOLUTION OF SPECIAL CNC MACHINES

The basic element of each CNC machine is the frame of the machine. This frame must have a definite resistance to wear; it must have the right stiffness. The CNC frame consists of nine basic parts with the characteristics that are important factors for machining precision. These factors include (Suh & Lee, 2008):

- Used good material
- Good static stiffness
- The constancy of the temperature
- Assurance of chip removal
- Efficient and simple production
- Ensuring the lowest possible weigh
- Ensuring the easiest possible handling

The frame of the CNC machine can be constructed using the different materials most commonly using steel or grey cast iron (Table 1). As a result of research and development, non-metallic materials such as concrete or polymer concrete can increasingly be encountered. The main factor for the correct material selection is the assessment of its properties (Table 2) that affect the operation of the equipment. An overview of the most commonly used materials for the production of CNC machine frames is given in the following table. The basic parts of the frame include drive systems, adjustable stops, guards, etc.

Table 1. Materials for the production of CNC machine frames

Metallic material	Non-metallic material	Combination of metallic and non – metallic material	Natural material
Cast iron	Plastic concrete		
Cast steel	Composites	Steel weldment with a filling of dampening material	Stone
Steel			

Table 2. Connection of material properties and technical properties of CNC machine

Material properties	Technical properties of a machine
Strength	Elimination of permanent deformation and fracture
Specific weight	Weight, static and dynamical properties
Modulus of elasticity	Static and dynamical stiffness
Reduction of vibration	Dynamical properties
Hardness	Friction and wear
Heat clearance	Thermal stability

From a functional point of view, the machine frame is the part of the machine which not only allows the distribution of all other functional groups of the machine in space but must also absorb all the reactions in the bearing arrangement of the drive members by its internal forces. These reactions are generally periodically variable; they can be the excitation forces of the frame oscillation. The frame must be dynamically stable so that its natural frequencies are significantly higher than the forced oscillations and that no resonance occurs (Figure 2).



Figure 2. Selected components of the frame

In addition to frames, linear rails are an essential part of CNC equipment. The primary function of the linear rail is to ensure accurate positioning of the elements that are movable in each axis. During the designing, it is necessary to observe the basic requirements for the linear rails, which include:

- Low passive resistance
- High rigidity of linear rails to eliminate vibration
- Simple and lightweight construction
- High abrasion resistance and therefore long service lifetime

The basic linear rail elements include supported ball bearing rods, unsupported ball bearing rods and profiled ball bearing rods. In the case of linear rails, it is possible to use different types of drives to which they are classified:

- Trapezoidal screws (Figure 3)
- Circular ball screws
- Timing belt



Figure 3. Trapezoidal screws

To ensure accurate movement and reliability in conjunction with accuracy, stepper motors are implemented in the CNC machine (Figure 4). Stepper motors are synchronous motors that are controlled by a uniform current. Rotation of the rotor by a certain step is ensured by a pulse that induces a magnetic field. According to its design is given the number of steps it takes. The number of steps is determined by the number of pole pairs. Servomotors are the second most common variant in the design of CNC machines. These motors have feedback and can handle the high overload. Stepper motors were applied to each axis to create consistency between frame, motor and electrical equipment.



Figure 4. Stepper motors

To control the stepper motors, a controller with a built-in four-axis card was used. The microcontroller of this card is ARM32. This card is suitable for all types of machines, where it is possible to connect other devices such as 3D print head or the laser head. The electronic card contains a network connection, which also provides remote control, so the controller is simple and easy to set up. This controller is attached to the structure and is protected by a cover.

A very important part of CNC machine construction consists of spindles, the use of which is determined by the specific type and performance. If the power of the spindle is higher, it can also be used for stiffer materials. The 500W spindle with external power supply, which is protected by an aluminium cover attached to the front of the machine, was chosen to create complex specifications of design solutions for special CNC machines. The advantages of this spindle include quiet operation and its weight. Various tools can be inserted into this spindle.

After a thorough analysis and specification of the necessary components, a 3D model was created. This model creation was of great importance in fine-tuning the details that could create problems in the actual production of the device. Based on the created model of CNC equipment was subsequently created also the drawing documentation, which is necessary for the subsequent production of the equipment.

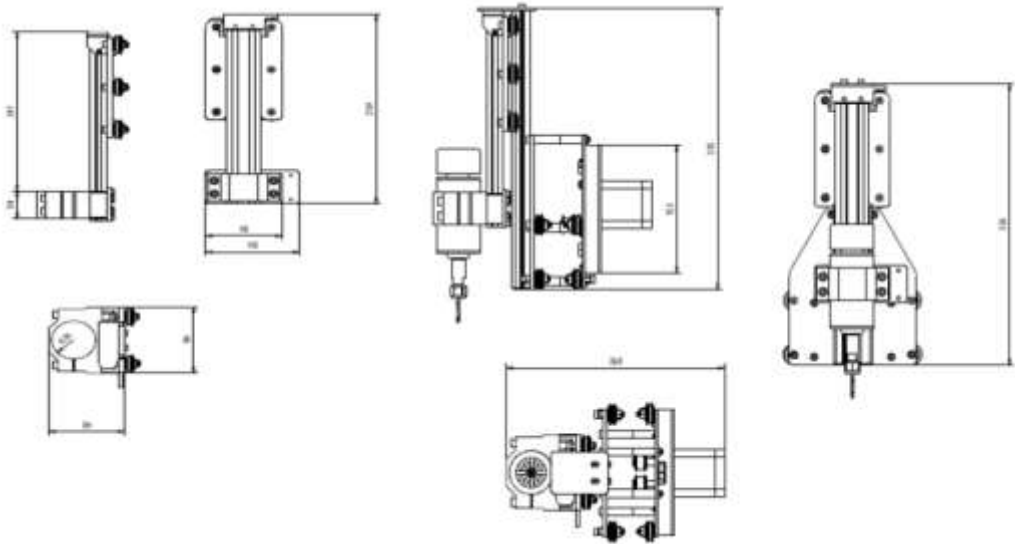

Figure 5. Example of mechanical drawing



Figure 6. 3D model of the elected representative's machine

CONCLUSIONS

The current trend of any production is rationalization and innovation. This is due to the widespread development of electronics, automation, material engineering and technology as a whole. This trend directly affects not only the production of the products themselves but also the production of machines and equipment, to which CNC milling machines undoubtedly belong. It is precisely because of innovation and rationalization that it is necessary to comprehensively specify the design basis for unconventional machine tools in these machine tools. The presented article was focused on the specification of the design basis of special CNC machines with a practical example of a selected representative. Although the designs of special CNC machines differ from one another, their construction must be based on generally applicable rules, which are determined and subsequently modified for specific cases.

ACKNOWLEDGEMENTS

This work was supported by the Slovak Research and Development Agency under the contract No. APVV-15-0700.

LITERATURE

Alkaios Bournias Varotsis. Introduction to CNC machining. (2020) from: <https://www.3dhubs.com/knowledge-base/cnc-machining-manufacturing-technology-explained/>

Antić, A., Kozak, D., Kosec, B., Šimunović, G., Šarić, T., Kovačević, D., & Čep, R. (2013). Influence of tool wear on the mechanism of chips segmentation and tool vibration. *Tehnički vjesnik*, 20(1), 105-112.

Behunova, A., Behun, M., & Knapcikova, L. (2018). Simulation Software Support of Manufacturing Processes in Engineering Industry. *TEM JOURNAL-TECHNOLOGY EDUCATION MANAGEMENT INFORMATICS*, 7(4), 849-853.

Kojic, D, Radičević, R., Erceg, T., Jotanović, M., Teofilović, V., Tanasić, L., & Vukić, N. (2015). The synthesis of polymer materials based on renewable resources, XVIII YuCorr, September 8-11, Tara Mountain, Serbia.

Mitalova, Z., Mital, D., Botko, F., Litecká, J., Zajac, J., Harnicarova, M., & Valicek, J. (2020). Identification of Topography of Surfaces Created by Turning Biomaterials with Optical Profilometry. *BioResources*, 15(2), 2483-2494.

Panda, A., Dyadyura, K., Valíček, J., Harničárová, M., Zajac, J., Modrák, V., ... & Pavelek, Z. (2017). Manufacturing technology of composite materials—principles of modification of polymer composite materials technology based on polytetrafluoroethylene. *Materials*, 10(4), 377.

Poklemba, R., Duplakova, D., Zajac, J., Duplak, J., Simkulet, V., & Goldyniak, D. (2020). Design and investigation of machine tool bed based on polymer concrete mixture. *International Journal of Simulation Modelling*, 19 (2), 291-302.

Suh, J. D., & Lee, D. G. (2008). Design and manufacture of hybrid polymer concrete bed for high-speed CNC milling machine. *International Journal of Mechanics and Materials in Design*, 4(2), 113-121.